

5 μ H Line Impedance Stabilisation Network

1 Introduction

The TBOH01 5 μ H LISN is a device required to setup conducted noise measurements of DC-powered devices. It is designed to be used for EMC pre-testing in the frequency range of 150kHz to 110 MHz according to the CISPR-25 standard.

The LISN is inserted into the supply line of the DUT (Device Under Test). Conducted noise which is present at the supply terminals of the DUT can be measured at the BNC connector using a spectrum analyzer or a measurement receiver. The source (supply) terminal and the DUT terminal are decoupled by a 5 μ H inductor.



1.1 Parameters

Frequency range: 100kHz – 110MHz (1GHz, see figure 4)

DC Resistance: 60 m Ω

Maximum current: 10A

Maximum source voltage: 200V

Built in surge protection

5 μ H Line Impedance Stabilisation Network

1.2 Schematic

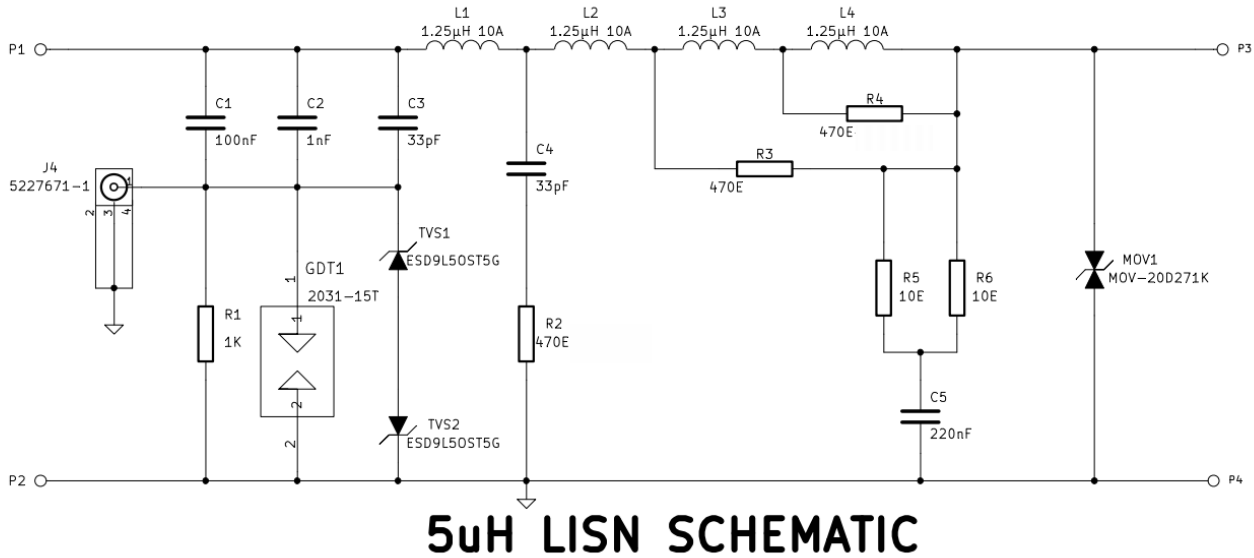

P1: DUT+; P3: Source+; CON1: Spectrum Analyzer / Measurement Receiver

BOM:

C1	C3216X7R2E104K	100nF 250V X7R 1206	TDK Corporation	Digikey
C2	1206PC102KAT1A	1nF 250V X7R 1206	AVX	Digikey
C3, C4	501R18N330JV4E	33pF 500V NP0 1206	Johanson	Digikey
C5	C3225X7R2E224M	220nF 250V X7R 1210	TDK Corporation	Digikey
CON1	DOSIN-801-0034	BNC 50 Ω 180° PCB mount	Dosin	Dosin
		Ms. Blanche Li	dosin2012@dosin-china.com	
GDT1	2031-15T-SM-RPLF	GAS TUBE 60V 1KA	Bourns Inc.	Digikey
HOUSING	1550DBK or 1550D	BOX ALUM 4.51X2.52X2.17"	Hammond	Digikey
L1, L2, L3, L4	1.25 μ H; 8 turns, \varnothing 17mm	\varnothing 1,4mm enamelled copper wire		
MOV1	MOV-20D271K	VARISTOR 270V 20MM	Bourns Inc.	Digikey
P1, P2, P3, P4	Banana Jacks			
PCB	5 μ H LISN V1.0	double sided, 95x58x1.6mm	FZ-Electronics	FZ
		Ms. Lisa Yang	lisyang@fzelectronics.com	
R1	RC1206FR-071KL	RES 1K OHM 1/4W 1% 1206	Yageo	Digikey
R2	RC1206FR-07470RL	RES 470 OHM 1/4W 1% 1206	Yageo	Digikey
R3, R4	4-1622820-8	RES 470 OHM 1W 5% 2512	TE Connectivity	Digikey
R5, R6	1622820-4	RES 10 OHM 1W 5% 2512	TE Connectivity	Digikey
TVS1, TVS2	ESD9L5.0ST5G	TVS ULT LOW CAP SOD-923	ON-Semiconductor	Digikey

5 μ H Line Impedance Stabilisation Network

1.3 Impedance

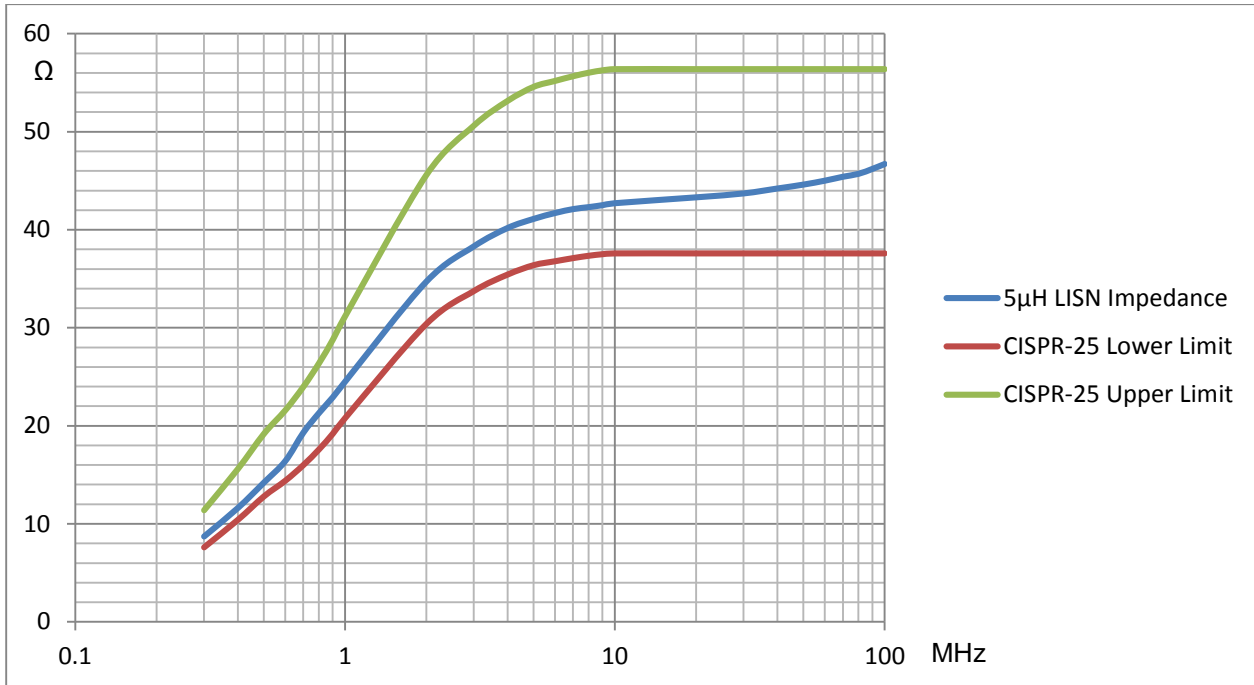

Picture 1 – 300kHz...100MHz, measured impedance of the 5 μ H LISN

1.4 Frequency response

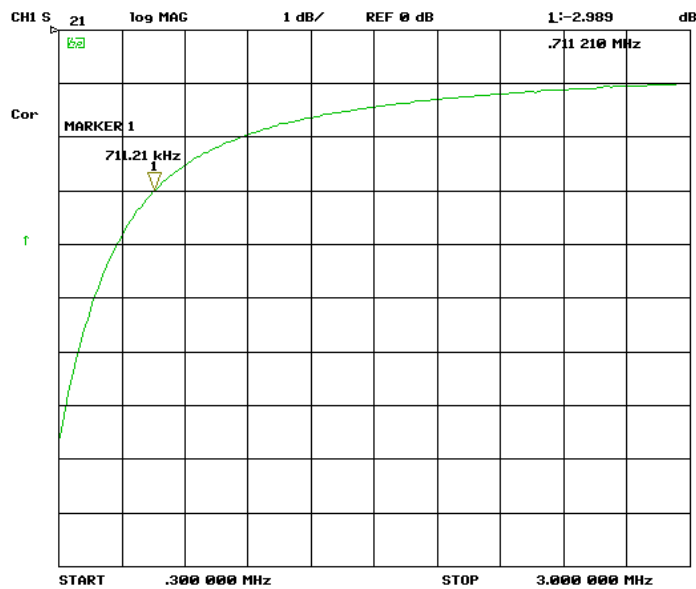

Picture 2 – 0,3...3MHz, insertion loss measured between DUT terminals and BNC connector; source terminals shorted

5 μ H Line Impedance Stabilisation Network

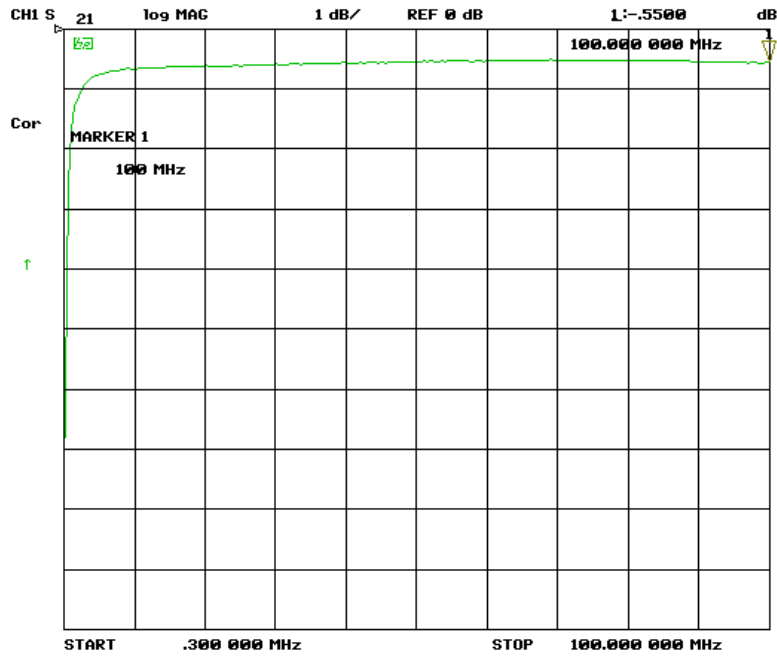

Picture 3 – 0,3...100MHz, insertion loss measured between DUT terminals and BNC connector; source terminals shorted

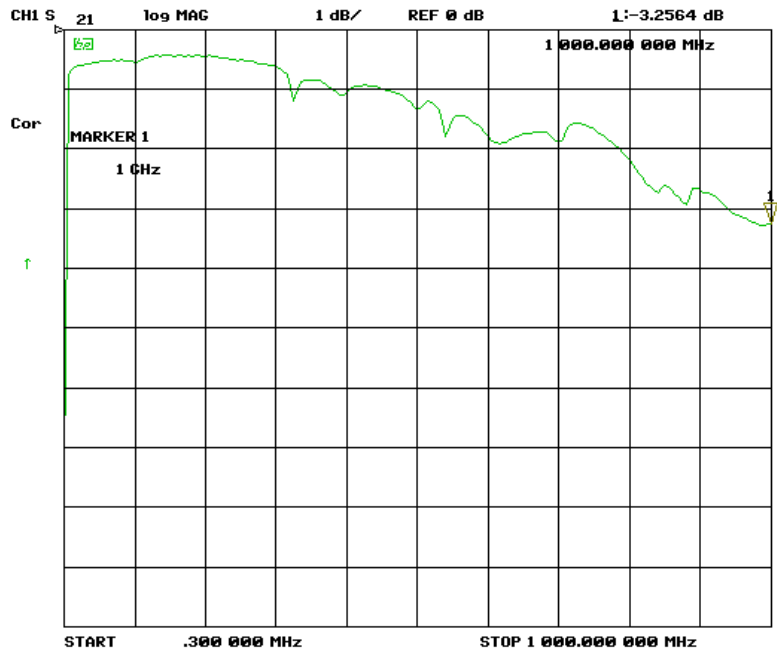

Picture 4 – 0,3...1GHz, insertion loss measured between DUT terminals and BNC connector; source terminals shorted

5 μ H Line Impedance Stabilisation Network

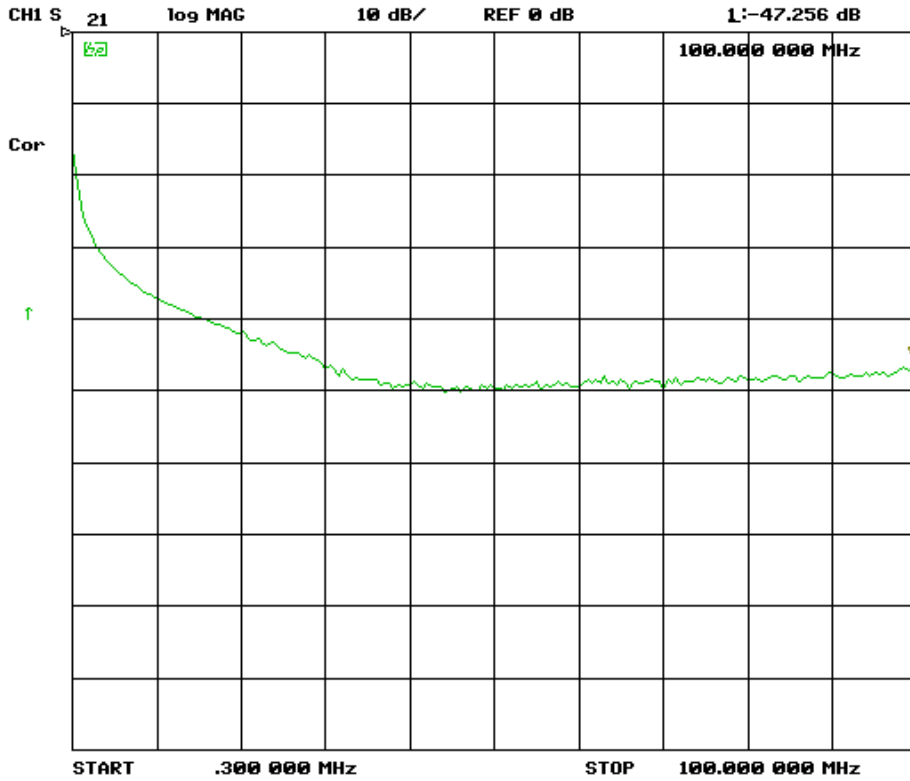

Picture 5 – 0,3...100MHz, isolation measured between DUT and source terminals; BNC connector terminated with 50 Ω

5 μ H Line Impedance Stabilisation Network

2 Application

A Line Impedance Stabilisation Network basically is a coupling device to measure conducted noise present on supply lines with a measurement receiver or spectrum analyzer.

A LISN has three terminals – both ends of a feedthrough pass for DC and a 50 Ω coaxial terminal to connect a measurement receiver or spectrum analyzer.

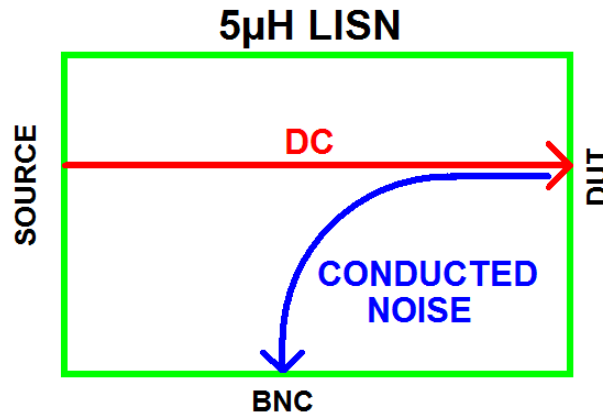

Picture 6 – basic functionality of a LISN

Conducted noise from the Device Under Test (DUT) is coupled from the supply line to a 50 Ω BNC terminal. Coupling loss from the DUT connector to the BNC connector is less than 1 dB from 3 MHz to 100 MHz. On the other hand, the LISN isolates the DUT and BNC terminals from conducted noise coming from the source side (Figure 5).

The DUT can be any DC powered electronic device. The Source can be any DC power supply up to 200V max.

Though the LISN is normally used to measure conducted noise from a DC powered device, it could also be used to inject RF to the supply lines of the DUT. This setup requires an additional 50 Ω feedthrough terminal at the BNC connector. Furthermore the LISN could be used to measure the noise of a source, for example a switched mode power supply or a DC/DC converter output. In this case, the power supply has to be connected to the DUT terminals and a load has to be connected to the Source terminals.

The test configurations shown in the following chapters are just examples and not strictly according to standards. They should rather serve as an easy means to carry out EMC pre-testing in the lab, before going to a certified test house.

Setup dimensions, Limits for spurious levels, bandwidth and detector settings for the measurement receiver or spectrum analyzer have to be derived from the applied standards.

Compliant measurements would make use of two LISNs, one in the positive and another one in the negative supply line and then alternatively measure the noise. For a precompliance measurement, measuring the positive supply line gives a good indication on the performance of the device. The measurement can then be repeated with the LISN inserted into the negative supply line to check if the noise levels are any different.

5 μ H Line Impedance Stabilisation Network

Professional conducted noise measurements are done in shielded chambers, as any RF smog picked up by the wires from LISN to DUT or by the DUT itself, will be present at the BNC terminal. Consequently, a measurement with the DUT powered off should be done upfront in order to distinguish between real conducted noise generated by the DUT and RF smog from other sources.

2.1 Standard Setup

Conducted noise measurements are typically conducted using a sheet metal as ground plane. The GND terminals of all involved devices are connected to the metal shield using short cables.

As the measurement will be conducted in lab, rather than in a shielded chamber, a background noise measurement should be carried out with the DUT switched off or disconnected in order to be able to differentiate between conducted noise spectrum and background electric smog.

The picture below shows a typical conducted emissions measurement setup, such as specified in CISPR-25 standard. Setup details will differ depending on the type of DUT and applicable standards.

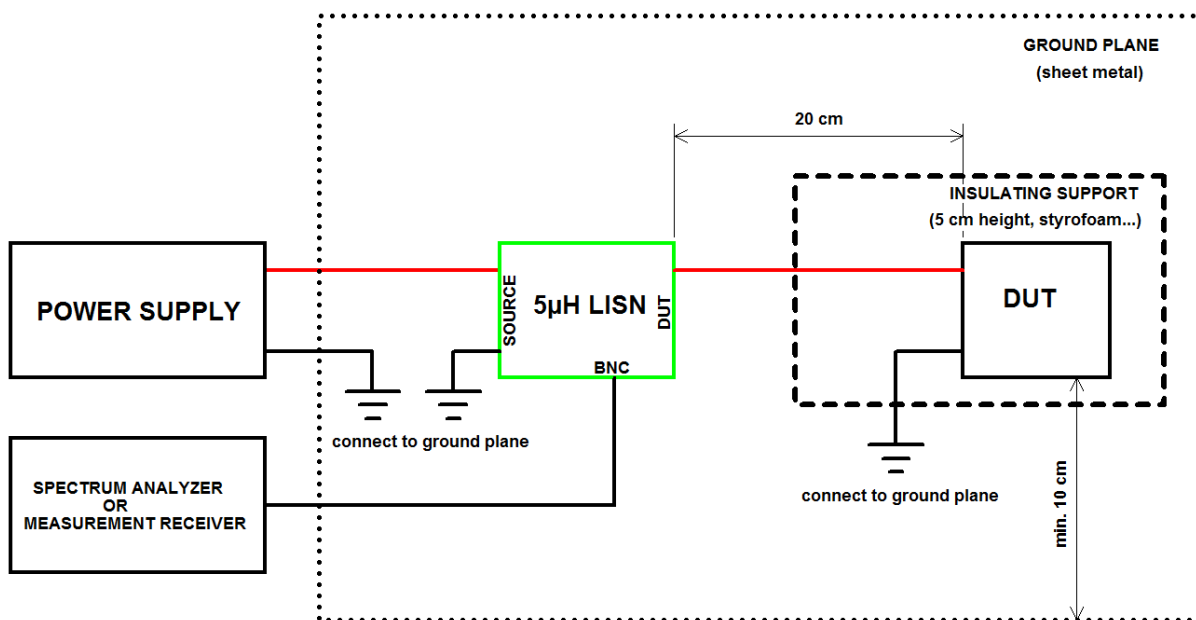

Picture 7 – example setup for a conducted noise measurement of a DC powered device

5 μ H Line Impedance Stabilisation Network

2.2 Setup for measuring power supply noise spectrum of power supplies

The LISN can also be used to measure noise spectrum at the output terminals of a power supply or switched mode regulator.

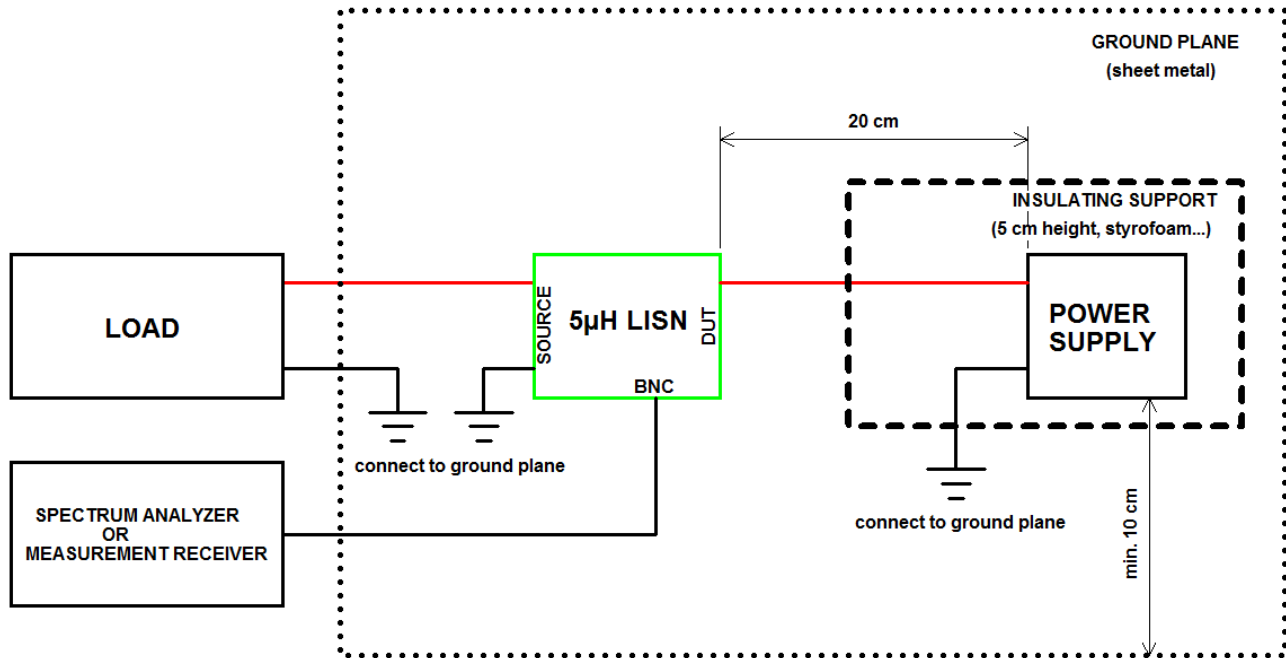

Picture 8 – setup for measuring power supply noise spectrum

Kindly notice again, that for exact set ups, you need to check the standards applicable to your DUT

5µH Line Impedance Stabilisation Network

2.3 Setup for RF immunity testing

By adding a 50 Ohm feed through termination, the LISN can also be utilized to inject RF into the supply line of the DUT. The power rating of the feedthrough termination has to match the injected RF power level.

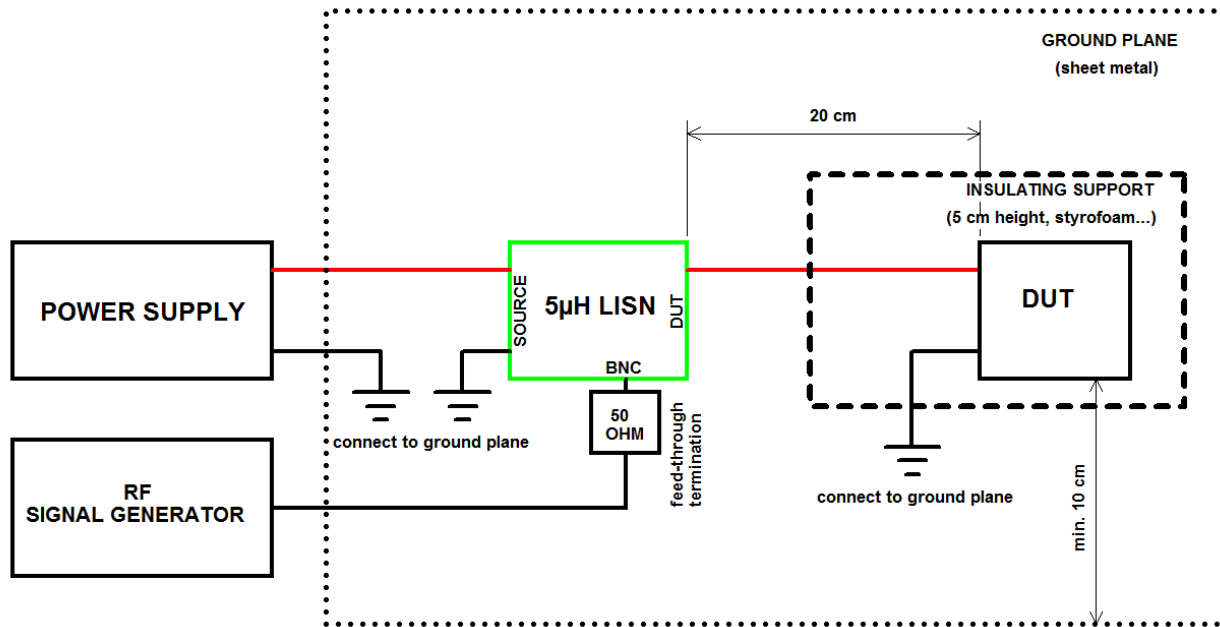

Picture 9 – setup for RF injection

3 CISPR 25 limits for broadband conducted emissions on power input terminals

CLASS	Levels in dBµV									
	0,15 – 0,3 MHz		0,53 – 2,0 MHz		5,9 – 6,2 MHz		30 – 54 MHz		70 – 108 MHz	
	Peak	Quasi Peak	Peak	Quasi Peak	Peak	Quasi Peak	Peak	Quasi Peak	Peak	Quasi Peak
1	113	100	95	82	77	64	77	64	61	48
2	103	90	87	74	71	58	71	58	55	42
3	93	80	79	66	65	52	65	52	49	36
4	83	70	71	58	59	46	59	46	43	30
5	73	60	63	50	53	40	53	40	37	24

For short duration disturbances, add 6 dB to the level shown in the table

Measuring instrument bandwidth (6 dB)			
Frequency band [MHz]		Broadband peak or quasi-peak	Narrowband peak or average
0,15 - 30		9 kHz	9 kHz
30 – 1000	FM Broadcast	120 kHz	120 kHz
	Mobile Service	120 kHz	9 kHz

The tables above are just an excerpt. Refer to the standard for further details.

5 μ H Line Impedance Stabilisation Network

4 Measurement Examples

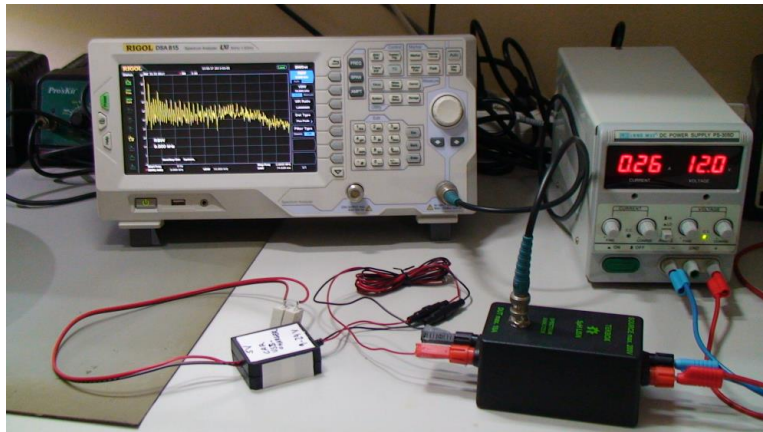

Picture 10 – simple laboratory set up

The picture above shows a simple set up to do a quick test of a 9V to 24V USB car charger adapter. The charger adapter gets supplied with 12 V at the DUT terminals of the LISN. The power supply is connected to the Source terminals of the LISN. A spectrum analyzer is connected to the BNC connector of the LISN.

Spectrum Analyzer settings:

Frequency: 150kHz - 3MHz

Detector Type: Positive Peak (use Max. Hold or Quasi Peak, if available)

Filter Type: EMI

BW: 9kHz

Internal Attenuator: OFF

Units: dB μ V

The setup is not CISPR25 conformant – no metal ground plane is involved. Nevertheless, the measurement permits a judgement of the conducted emission performance of the DUT and will be very useful to determine, if modifications of the circuit result in improved suppression of conducted emissions.

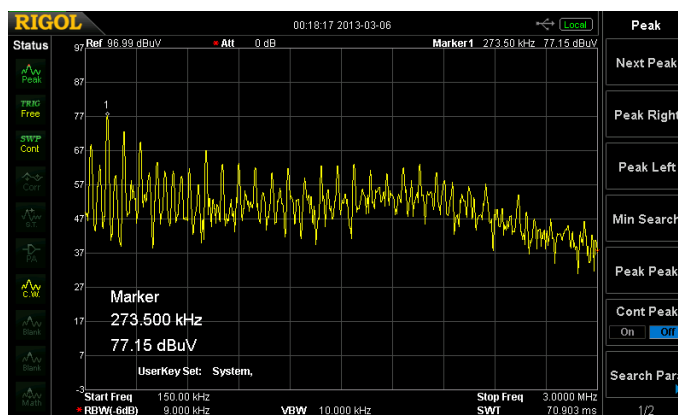

Picture 11 – conducted emissions, frequency range 150kHz to 3MHz

The screenshot of the spectrum analyzer shows the spurious of the switched mode DC/DC converter. With reference to the CISPR 25 limits it would be around Class 4, given the setup would be conformant with the standard.

5 μ H Line Impedance Stabilisation Network

5 History

Version	Date	Author	Changes
V1.0	14.09.2010	L.D.HIEU	Creation of the document
V1.1	18.11.2013	L.D.HIEU	Chapter 2 updated
V1.2	17.03.2014	L.D.HIEU	Part number of R2 corrected

Table 1 – History